

# The Science of Golf

## Test Lab Toolkit **The Ball: Aerodynamics**

Grades 6-8

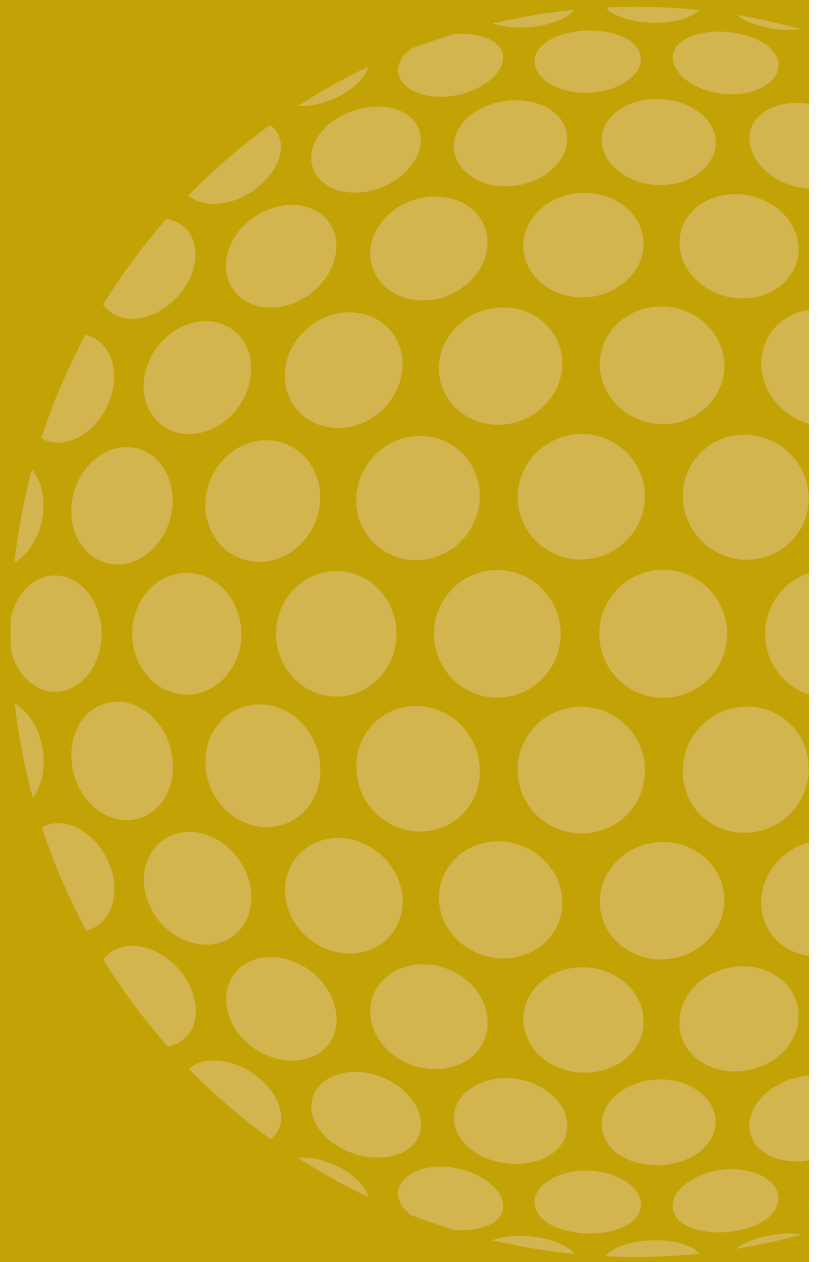

Science



Technology



Engineering



Mathematics



---

## Table of Contents

Welcome to the Test Lab	02
Investigate: Bernoulli's Principle	03
Investigate: Wind Tunnel	06
Create: Paper Airplane Tournament	10
Connect: Sports Swap	13
Key Concepts	16

Test Lab Toolkits bring math and science to life by showing how STEM studies play a big role in the game of golf. They are funded by the United States Golf Association (USGA).

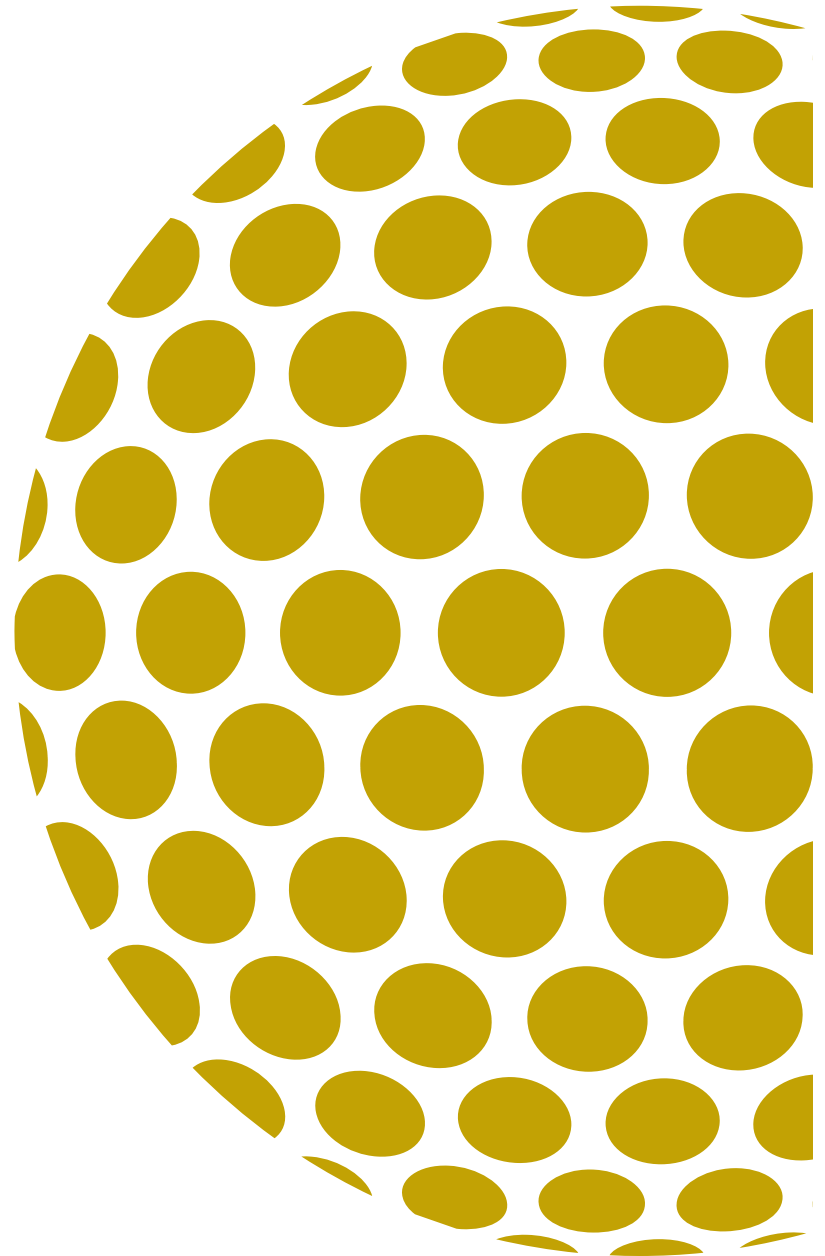

# Welcome to the Test Lab Toolkit!

Aerodynamics

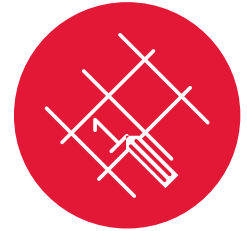
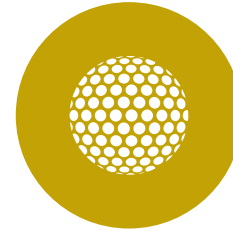

Sometimes the study of science and math can seem a little disconnected from the “real” world, a little irrelevant, a little boring. Yet a closer look reveals that science and math are everywhere in the world around you, in familiar and surprising ways.

Take something fun, like the game of golf. Sure, there’s math, because you have to keep score. But there’s also lots of science, technology, and engineering hidden in the game — from the physics of how you swing, to the mechanics of a golf club, to the remote sensors that tell you when to water the golf course.

At the United States Golf Association Test Center, scientists and engineers play around with golf balls, clubs, and other equipment every day so that they can

learn more about how they work. Since people keep thinking of new ways to improve the game, the USGA needs to constantly test new equipment to make sure it doesn’t interfere with the game’s best traditions or make game play unfair.

How does the USGA Test Center study this stuff? With golf ball cannons, robot clubs, and other cool experiments. And now you can do some of the very same experiments with the **TEST LAB TOOLKITS**, which let you set up your own test center in your club, class, or at home.

In this Toolkit, you’ll explore the science of **AERODYNAMICS** through activities that let you:

- 1 Experiment with air pressure (and learn about Bernoulli’s Principle)
- 2 Build a wind tunnel (and investigate how drag affects the flight of a ball)

3 Design your own paper airplane (and figure out how to make it go farther than anyone else’s)

4 Mix up equipment from different sports (and discover how it changes the game)

For every experiment you try, record your results with photos, diagrams, or any way you like, and then put it all together into your own Test Lab Log. The more Toolkits you do, the more of a golf (and science) expert you’ll become!

Ready to explore the science and math behind the world’s greatest game?

# Investigate: Bernoulli's Principle

Aerodynamics



Grades **6-8**



## How does air pressure keep a golf ball in the air?

At the USGA Test Center, scientists examine every aspect of a golf ball — its weight, shape, size, materials, and how it flies. For the last part, they need to understand the science of **aerodynamics**, or how objects move through the air. Air continually exerts **pressure** (or pushing power) on everything it surrounds.

The faster the air moves, the less pressure it exerts — an effect called **Bernoulli's Principle**. In this activity, you'll investigate the relationship between low and high pressure by seeing Bernoulli's Principle in action.

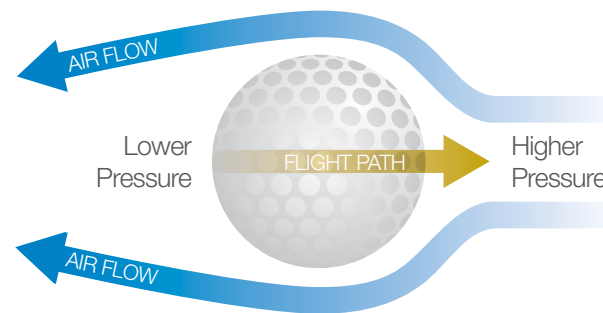

Air Pressure

## What Do You Need?

2 pieces of paper (8½ by 11)

3 Ping Pong Balls

String

Scissors

Chopstick (or other stick)

Tape

Straw





## What Do You Do?

- Before each of these experiments, think about where the air will have lower or higher pressure (where it is moving faster or slower). Predict what will happen, and then see if you're right.
- Parallel Paper:** Hold two sheets of paper so that they hang down parallel to each other, about 4 inches apart. Blow between them. What happens?
- Paper Tent:** Fold a sheet of paper in half. Rest it on a table so that it makes a "tent." Blow inside the tent. What happens?
- Hanging Ping Pong:** Cut 2 pieces of string, 1 foot long. Tape one end of each to a ping pong ball. Tape the other end of each string to a chopstick, about 3 inches apart. Hold the chopstick horizontally in front of you, and blow between the balls. What happens?
- Funnel:** Roll a piece of paper into a cone and tape it together to make a funnel. Tape a straw to the bottom, so that no air can escape between the paper and straw. Hold the funnel so that the bowl faces up and the straw is on the bottom. Put a ping pong ball inside the funnel. Put your head under the funnel, and blow hard into the straw.
- Then turn the funnel upside down, so that the straw is on top. Put the ball inside the funnel again, and hold it in place against the funnel bottom with your finger. Start blowing hard in the straw and remove your finger while blowing. What happens?

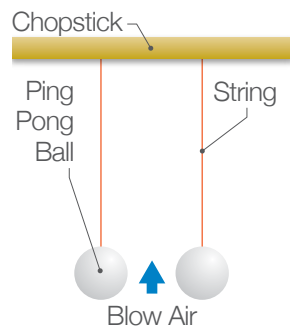

Ping Pong Experiment

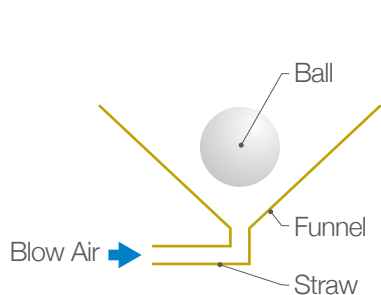

Funnel Experiment 1

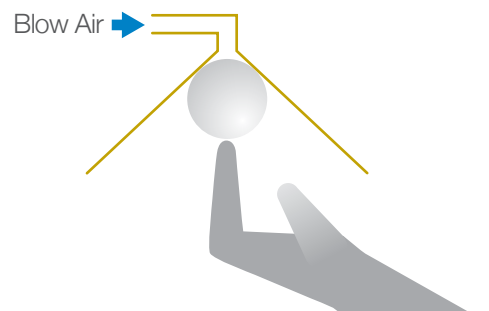

Funnel Experiment 2

## What Happens?

Use the chart to record your results, and make more as needed.

## What Does it Mean?

- What did you learn about air pressure?
- If a golf ball with backspin causes the air on top of it to move faster than the air under it, how would that lower air pressure (faster moving air) affect the ball?

## Challenge!

Using the same materials, or others, can you create your own experiment that proves Bernoulli's Principle?

## Find Out More

- Read *Key Concepts* at the back of this Toolkit.
- Read *Aerodynamics: Background Information*.
- Watch the NBC Learn video "Evolution of the Golf Ball" at [www.nbclearn.com/science-of-golf](http://www.nbclearn.com/science-of-golf).



Experiment	What Will Happen?	What Did Happen?	Where is the Low Pressure Air?	Where is the High Pressure Air?
Parallel Paper	<i>Prediction</i>	<i>Result</i>	<i>Location</i>	<i>Location</i>
Paper Tent				
Hanging Ping Pong				
Funnel				

 Add this chart to your Test Lab Log!

# Investigate: Wind Tunnel

Aerodynamics



Grades **6-8**



## How does drag affect how a ball flies through the air?

The hit from a club starts the golf ball moving, but how far it flies depends in part on how aerodynamic it is. The aerodynamic force called **lift** makes the ball move upward — the more lift it has, the farther it will go. At the same time, wind resistance pushes back against the ball, creating a force called **drag**, which slows the ball down. The USGA Test Center uses a high-speed robot launcher to shoot golf balls at speeds up to 200 mph so that they can measure their aerodynamics. In this activity, you'll make your own wind tunnel to see which balls cause the least drag and fly most easily.

## What Do You Need?

- Portable fan
- Large cardboard box
- Quart-size milk cartons, at least 12, more depending on the size of your box
- 1 or more sheets of acetate (available at an art or office supply store)
- Posterboard
- Masking tape
- Scissors
- Markers in different colors
- String
- Tissue paper, paper strip, or lightweight fabric

- Golf ball and other light balls with different weight, size, texture, etc.
- Tape measure (optional)
- Scale (optional)
- Protractor (optional)

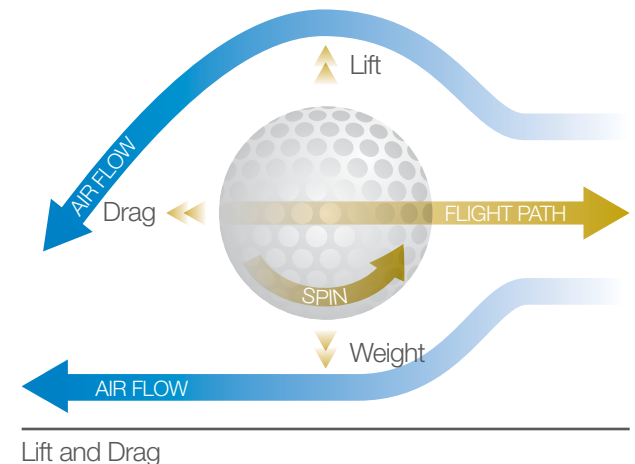



## What Do You Do?

- 1 Get a large cardboard box, more rectangular than square. The short end should be approximately the same size as the fan (or as close as possible). Cut off the two short ends, so that air can easily pass through the box.
- 2 Cut a square window out of the middle of one long side. Tape a sheet of acetate over the window, so that you can see into the box.
- 3 Cut the ends off the milk cartons, stack them together, and tape them, so that they form a grid that fits inside the box at one end. They should extend no more than 1/3 of the way along the box, not past the window. If the cartons are too long, cut them shorter. This grid will even out the air from the fan.
- 4 Place the fan at the grid end of the box, as close to it as possible, facing inside. If there is extra room between the fan and the edges of the box, cut pieces of posterboard and tape them over the open spaces, so that all the air is directed into the box.
- 5 Make a small hole on the top of the box, in the middle of the window area.
- 6 Your wind tunnel is ready to use! First attach a small piece of tissue paper to a piece of string with tape. Thread the string through the hole at the top of the box, position the tissue paper so that it hangs in the middle of the tunnel, and tape the string to the top.
- 7 Turn the fan on and record how far forward the paper moves. Try different fan speeds.
- 8 Now use the wind tunnel with different balls. If you want to be precise, you can weigh each ball and measure its diameter. For each ball, attach it to a string, position it so that it hangs in the middle of the tunnel, and tape the string (through the hole) to the top of the box. Turn the fan on and try different speeds.
- 9 You can use a marker on the acetate to draw the position of the string when the fan is off and at different speeds, and then use a protractor to measure the angles. Use a different sheet of acetate for each ball, or a different color marker on the same acetate.

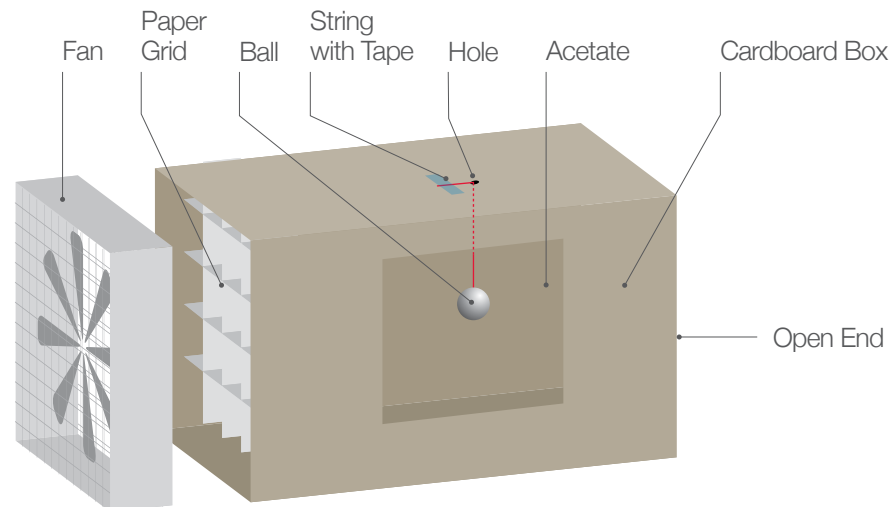





---

## What Happens?

Use the chart to record your results, and make more as needed.

---

## What Does it Mean?

- What seems to have the biggest effect on decreasing drag and making a ball fly forward more easily — weight, size, texture, something else?
- How did the golf ball compare to the others?
- Why do you think the USGA regulates golf ball design?

---

## Find Out More

- Read *Key Concepts* at the back of this Toolkit.
- Read *Aerodynamics: Background Information*.
- Watch the NBC Learn video “Evolution of the Golf Ball” at [www.nbclearn.com/science-of-golf](http://www.nbclearn.com/science-of-golf).



Ball	Weight ounces	Diameter inches	Texture	Angle at Fan Speed 1 degrees	Angle at Fan Speed 2 degrees	Angle at Fan Speed 3 degrees
Golf Ball	1.6	1.7	dimpled	5	10	20

 Add this chart to your Test Lab Log!

# Create: Paper Airplane Tournament

Aerodynamics



Grades **6-8**



## What kind of paper airplane flies the best?

Even small design changes can greatly increase a ball's **lift** (the force that makes it go up) and decrease its **drag** (the force that slows it down), which in turn affect how far the ball can go. That's why the USGA sets specific standards for golf ball design (weight, size, shape, speed, etc.) and tests more than 30,000 balls per year to make sure they meet those standards. In this activity, you'll use what you've learned about **aerodynamics** to design a paper airplane, and see if you can make yours go farther than anyone else's!

## What Do You Need?

Copy paper (8½ by 11)

Other types of paper (optional)

Scissors

String

Materials that could be added to a plane (paperclips, tape, glue, staples, etc.)

Tape measure (optional)

Stopwatch

How to Make a Paper Airplane

### Step 1

Fold the paper in half lengthwise. Run your thumbnail along the fold to make it sharp. Then unfold it.

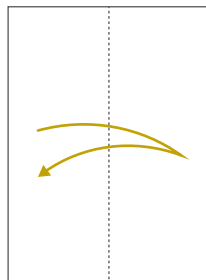

### Step 2

Fold down the top corners so that they meet in the middle.

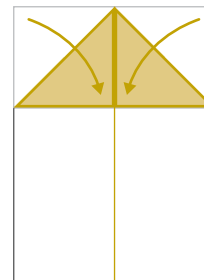

### Step 3

Fold the two top edges toward the center line.

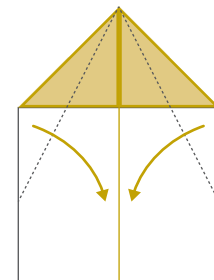

This activity is adapted from Amazing Paper Airplanes ([www.amazingpaperairplanes.com/Basic\\_Dart.html](http://www.amazingpaperairplanes.com/Basic_Dart.html))

The Science of Golf





## What Do You Do?

- 1 If you haven't done the *Investigate* activities in this Toolkit, read *Aerodynamics: Background Information*.
- 2 Use a piece of paper to make a standard dart plane, following the instructions in the illustrations.
- 3 Go to a large open space. Create a starting line on the ground with string or tape. Practice flying your plane. Record how far it goes and how long it stays in the air. You can estimate measurements, or use a tape measure and stopwatch if you want to be precise.
- 4 Then decide if you want to modify the plane's shape or weight to try to reduce drag and increase lift. For example, you could:
  - Bend up the tip of the wings
  - Add glue, tape, or paperclips for weight
  - Use a different kind of paper
  - Try a different folding technique (see [www.bestpaperairplanes.com](http://www.bestpaperairplanes.com))
- 5 When all the planes are ready, have the tournament. Fly each plane from the starting line. Each person has 3 chances to get the best time and distance.
- 6 Did you win? If not, make a new plane and try again!

How to Make a Paper Airplane, continued

### Step 4

Fold the plane in half again, as you did in Step 1, so that the other folds are on the inside.

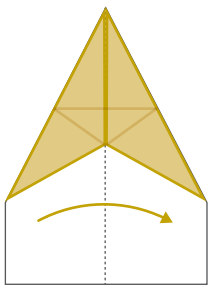

### Step 5

Turn the plane 90 degrees. Fold down one side to create a wing. The folded wing should extend past the paper underneath. Flip the plane over and repeat on the other side.

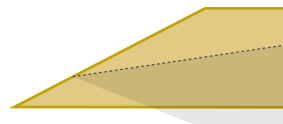

### Step 6

Form the 3D plane by holding the long paper fold vertically and lifting the wings up so that they are horizontal.

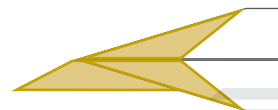

## What Happens?

Use the chart to record your results, and make more as needed.

## What Does it Mean?

- Which airplane flew the farthest and why?
- What did you learn about the forces of lift and drag?

## Find Out More

- Read *Key Concepts* at the back of this Toolkit.
- Read *Aerodynamics: Background Information*.
- Watch the NBC Learn video "Evolution of the Golf Ball" at [www.nbclearn.com/science-of-golf](http://www.nbclearn.com/science-of-golf).



Plane Model	Paper Type	Change Shape?	Change Texture	Change Weight?	Distance	Time in the Air
<i>Standard Dart</i>	<i>Copy Paper</i>	<i>No</i>	<i>No</i>	<i>No</i>	<i>15 feet</i>	<i>5 seconds</i>

 Add this chart to your Test Lab Log!

# Connect: Sports Swap

Aerodynamics



Grades **6-8**



## Why do different sports use such different balls?

Many sports use a ball. But the balls are designed for different purposes — hitting (golf), throwing (baseball), kicking (soccer), and more. And the **aerodynamics** of each is different also, with different balls better for travelling short or long distances, or bouncing, or flying high. How well-suited is each ball to its own sport? In this activity, you'll mix up sports and balls to find out!

## What Do You Need?

A variety of balls from different sports (golf, tennis, basketball, etc.)

Equipment used with each ball (golf club, tennis racket, etc.)

Scale (optional)

Tape measure (optional)

Stopwatch (optional)





## What Do You Do?

- 1 Take a look at all the balls you have. How are they different in terms of weight, size (diameter), shape, and texture? You can estimate measurements, or use a scale and tape measure if you want to be precise.
- 2 Go to a large open space. Try throwing each ball. Record how far it goes, how long it stays in the air, and how it feels to throw it.
- 3 Try each piece of equipment with each ball. For example, try using the golf club with each of the balls, then the tennis racket, and so on. What happens?
- 4 Try playing a full game that mixes equipment from different sports — for example, play basketball with a ping pong ball. What happens?



## What Happens?

Use the charts to record your results, and make more as needed.

## What Does it Mean?

- Why do you think the balls are made the way they are?
- How does changing the ball change the sport?
- Why is a golf ball the best ball to use for golf?

## Find Out More

- Read *Key Concepts* at the back of this Toolkit.
- Read *Aerodynamics: Background Information*.
- Watch the NBC Learn video “Evolution of the Golf Ball” at [www.nbclearn.com/science-of-golf](http://www.nbclearn.com/science-of-golf).



**Ball Throw (Step 2)**

Ball	Weight	Diameter	Shape	Texture	Distance Thrown	Time in the Air	Feel of the Throw
<i>Golf</i>	<i>1.6 ounces</i>	<i>1.7 inches</i>	<i>sphere</i>	<i>dimpled</i>	<i>30 feet</i>	<i>5 seconds</i>	<i>light</i>

**Equipment Swap (Step 3)**

Ball	Equipment	What Do You Think Will Happen?	What Did Happen?	Is the Sport Easier or More Difficult with the Different Ball?
<i>Golf</i>	<i>Baseball bat</i>	<i>Will hit it far</i>	<i>Too small to hit easily</i>	<i>More difficult</i>

 Add this chart to your Test Lab Log!





## Aerodynamics

The science of how objects move through the air. The word comes from the combination of the Greek words *aeroes* (of the air) and *dynamis* (power, strength, force).

## Airflow

The motion of air. In the case of a golf ball, airflow refers to how air moves around and/or past a ball as it travels.

## Air Pressure

A force caused by air pressing (or pushing) on an object. Air continually exerts pressure on everything it surrounds.

## Bernoulli's Principle

A scientific principle that states that moving air causes less pressure on an object than still air. This is also true of moving fluids (like water).

## Dimples

Dents on a golf ball that help it travel farther through the air. They do this by creating turbulence in the airflow around the ball, which reduces drag.

## Drag (Air Resistance)

A force created by air pushing back against a moving object, which causes it to slow down. Most round objects (like a golf ball) have less drag than flat objects (like a cube).

## Flight Path

The direction in which a golf ball travels through the air.

## Force

The means by which an object is pushed or pulled.

## Golf Ball (Featherie)

In the 17th century, golf balls were created by stuffing a wet leather pouch with goose feathers and sewing it up, which then shrank into a hard, compact ball as it dried. Featheries could fly better than earlier wood balls, but were expensive to make and very fragile.

## Golf Ball (Guttie)

In the mid-19th century, golf balls were made out of gutta-percha (a rubbery sap from tropical sapodilla trees). Gutties were more solid and resilient than featheries, so they could bounce better and fly faster, but also stop quickly when landing.



### Golf Ball (Modern)

Golf balls today have as few as one or as many as six different layers of solid material, usually polymers such as polybutadiene (a highly resilient synthetic rubber that is also used in car tires).

### Gravity

A force of attraction that pulls objects toward each other. The more mass an object has, the stronger its gravitational pull.

### Lift

A force that lifts an object upward due to the difference between the air pressure above and below it. The air moving over the top of a golf ball travels faster than the air below it, causing the ball to move upward.

### Mass

The amount of matter in an object. The more mass an object has, the more force is required to move it.

### Newton's Laws of Motion

Scientific principles established by English scientist Isaac Newton in the 17th century. *First law:* an object at rest will stay at rest, or an object in motion will stay in motion at a constant speed, unless an external force acts on it. *Second law:* when a force acts on an object, the object will move in the same direction that the force was moving. *Third law:* any object will react to a force applied to it, and the force of the reaction will be equal to and in the opposite direction of the original force applied.

### Speed

The measure of how fast an object travels a specific distance over a specific time.

### Spin

The circular motion of a golf ball as it travels through the air. As a ball moves forward through the air, the dimples cause the ball to actually spin backwards, pulling the airflow downwards. As this happens, the air at the bottom of the ball pushes up against the ball, creating more lift.

### Turbulence

Irregular or agitated motion of the air. You can feel this when an airplane encounters turbulence and starts to shake.

**Velocity**

The measure of speed in a specific direction.

**Weight**

The measure of the pull of gravity on the mass of an object. The weight of an object makes it harder to lift or stay aloft in the air.